

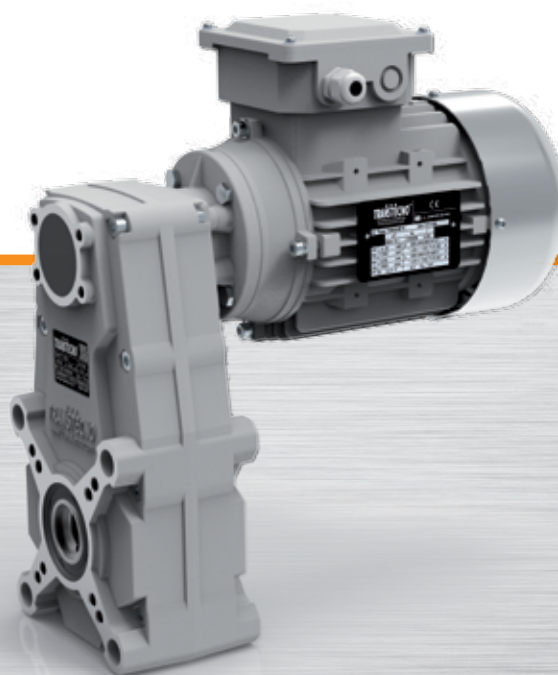

Motoriduttori pendolari
Helical parallel gearmotors

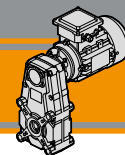



Indice	Index	Pag. Page
Caratteristiche tecniche	<i>Technical features</i>	E2
Designazione	<i>Classification</i>	E2
Sensi di rotazione	<i>Direction of rotation</i>	E3
Simbologia	<i>Symbols</i>	E3
Lubrificazione	<i>Lubrication</i>	E3
Carichi radiali	<i>Radial loads</i>	E4
Dati tecnici	<i>Technical data</i>	E5
Dimensioni	<i>Dimensions</i>	E8

Questa sezione annulla e sostituisce ogni precedente edizione o revisione. Qualora questa sezione non Vi sia giunta in distribuzione controllata, l'aggiornamento dei dati ivi contenuto non è assicurato. **In tal caso la versione più aggiornata è disponibile sul nostro sito internet www.transtecno.com**

This section replaces any previous edition and revision. If you obtained this catalogue other than through controlled distribution channels, the most up to date content is not guaranteed. In this case the latest version is available on our web site www.transtecno.com

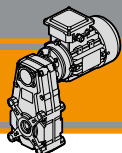

Caratteristiche tecniche

Technical features

I motoriduttori pendolari della serie FT hanno le seguenti caratteristiche principali:

- Carcasa in pressofusione di alluminio
- Lubrificazione permanente con olio sintetico.
- Ingranaggi cilindrici a denti elicoidali, induriti e rettificati.

FT helical parallel gearmotors range has the following main features:

- Die-cast aluminium housings
- Permanent synthetic oil long-life lubrication.
- Ground-hardened helical gears.

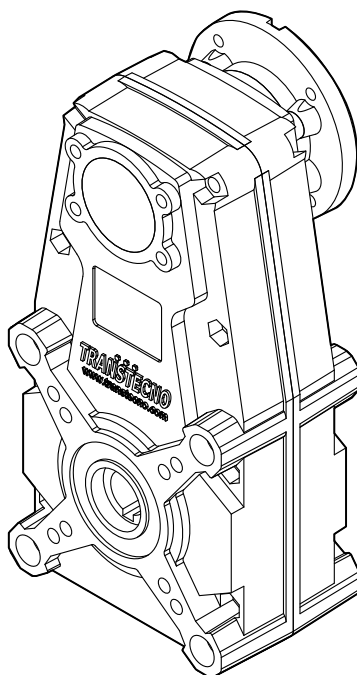

Designazione

Classification

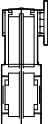
RIDUTTORE / GEARBOX						
FT	146	U	60.63	O20	56	B5
Tipo Type	Grandezza Size	Versione Version	Rapporto Ratio	Albero cavo uscita Hollow output shaft	IEC 	Forma costruttiva Version
	105/3 105/4 146 196	U...	vedi tabelle see tables	vedi tabelle see tables	56 63 71 80 90	B5 B14

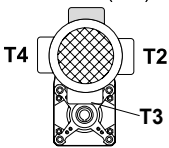
MOTORE / MOTOR					
0.09kW	4p	3ph	230/400V	50Hz	T1
Potenza Power	Poli Poles	Fasi Phases	Tensione Voltage	Frequenza Frequency	Pos. morsetteria Terminal box pos.
vedi tabelle see tables	2p 4p 6p 8p	1ph 3ph	230V 230/400V	50Hz 60Hz	T1 (Std) 

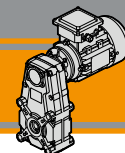

Sensi di rotazione

Direction of rotation

FT105/3
FT146
FT196

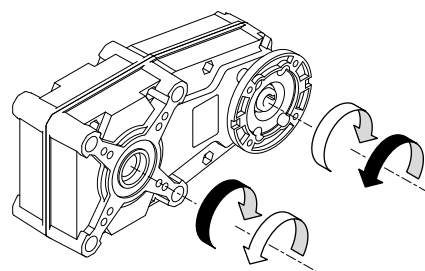
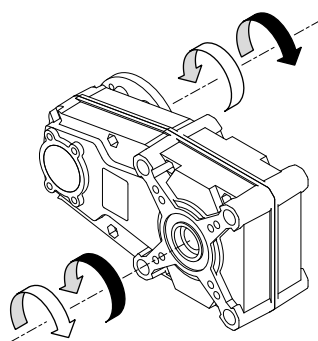

FT105/4

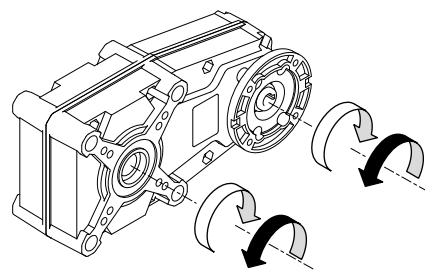
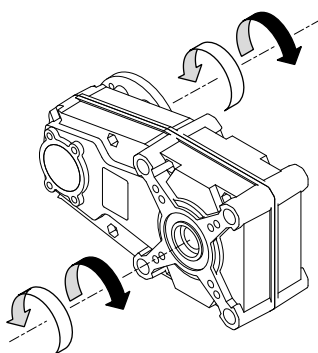

Simbologia

Symbols

n_1	[min ⁻¹]	Velocità in ingresso / <i>Input speed</i>
n_2	[min ⁻¹]	Velocità in uscita / <i>Output speed</i>
i		Rapporto di riduzione / <i>Ratio</i>
P_1	[kW]	Potenza in entrata / <i>Input power</i>
M_2	[Nm]	Coppia nominale in uscita in funzione di P_1 / <i>Output torque referred to P_1</i>
P_{n1}	[kW]	Potenza nominale in entrata / <i>Nominal input power</i>
M_{n2}	[Nm]	Coppia nominale in uscita in funzione di P_{n1} / <i>Nominal output torque referred to P_{n1}</i>
sf		Fattore di servizio / <i>Service factor</i>
R_2	[N]	Carico radiale ammissibile in uscita / <i>Permitted output radial load</i>
A_2	[N]	Carico assiale ammissibile in uscita / <i>Permitted output axial load</i>

Lubrificazione

Lubrication

Tutti i motoriduttori sono forniti completi di lubrificante sintetico viscosità 320, pertanto possono essere installati in qualunque posizione di montaggio e non necessitano di manutenzione.

Permanent synthetic oil long-life lubrication (viscosity grade 320) makes it possible to use the gearmotors in all mounting positions; for this reason they can be installed in any assembly position and do not require maintenance.

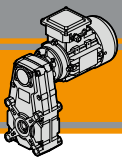

Carichi radiali

Radial loads

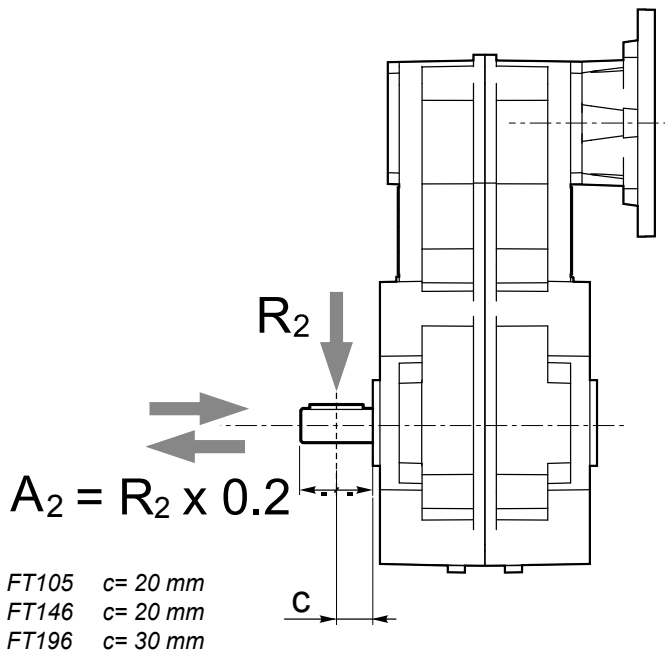

n_2 [min ⁻¹]	R_2 [N]		
	FT105	FT146	FT196
70	1500	2500	3500
40	1700	2700	4000
30	1850	2850	4600
20	2000	3000	5500
10	2000	3000	7000
5	2000	3000	7000

Quando il carico radiale risultante non è applicato sulla mezza-
ria dell'albero occorre calcolare quello effettivo con la seguente
formula:

When the resulting radial load is not applied on the centre line
of the shaft it is necessary to calculate the effective load with the
following formula:

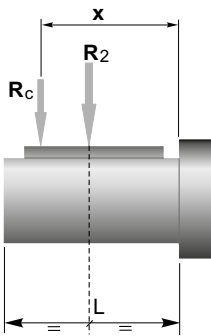

	FT105	FT146	FT196
a	82	82,5	132
b	62	62,5	102
R_{2MAX}	2000	3000	7000

$$R_c = \frac{R_2 \cdot a}{(b+x)} \leq R_{2MAX}$$

$$R \leq R_c$$

a, b = valori riportati nella tabella
a, b = values given in the table

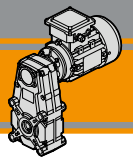

Dati tecnici

n₁ 1400 min⁻¹

Technical data

	n ₂ [min ⁻¹]	Mn ₂ [Nm]	Pn ₁ [kW]	i	IEC Motori applicabili IEC Motor adapters			
FT105					56B14			
FT105/3	68	40	0.30	20.57				
	42	50	0.23	33.32				
	32	65	0.23	44.36				
	26	65	0.18	54.87				
	20	65	0.14	71.84				
	18	65	0.13	77.07				
	16	65	0.11	88.87				
	11	65	0.081	124.81				
	7.7	65	0.056	181.35				
	6.2	65	0.045	224.32				
4.4	65	0.032	315.05					
FT105/4	3.8	65	0.028	368.19				
	2.6	65	0.019	534.98				
	2.1	65	0.015	661.76				
	1.5	65	0.011	929.40				
FT146					56 B5/B14	63 B5/B14	71 B5/B14	
	75	80	0.65	18.75				
	53		0.47	26.17				
	50		0.43	28.26				
	40	100	0.44	35.07				
	35		0.39	39.44				
	30		0.33	46.44				
	26		0.29	52.86				
	23	110	0.28	60.63				
	20		0.24	70.00				
	17		0.20	84.63				
	15		0.18	95.61				
	12		0.15	113.40			*	
	10		0.13	133.45			*	
	9.3	0.11	150.18			*		
8.7	120	0.11	160.43			*		
7.8		0.10	178.83			*		
6.3		0.082	223.92			*		
5.9		0.077	236.83			*		
4.7		0.061	300.07		*	*		
4.7		0.061	300.07		*	*		
3.5		0.046	397.38		*	*		
FT196					71 B5/B14	80 B5/B14	90 B5/B14	
	69	350	2.6	20.41				
	40	400	1.8	34.81				
	33	450	1.6	42.61				
	24	500	1.3	59.36				
	19	550	1.1	72.68				
	15		0.92	92.82				
	11		0.69	123.95				
	8.9		0.51	158.02				
	6.9		0.42	201.80				
	5.2		0.32	269.47				

FT

N.B.
Le aree evidenziate indicano l'applicabilità della corrispondente grandezza motore.

* = Il fattore di servizio (sf) deve essere scelto in funzione dell'applicazione: si prega di contattare il nostro Servizio Tecnico.

Prima di eseguire la scelta del motoriduttore riferirsi alle prestazioni elencate nelle tabelle pag. E6.

N.B.
Highlighted areas indicate motor inputs available on each size of unit.

* = The service factor (sf) has to be selected depending on application: please contact our Technical Department.

Before selecting any gearbox, please read the performance values shown in the tables on page E6.

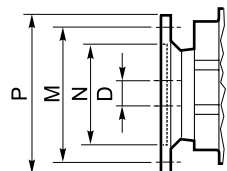



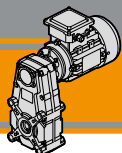

Dimensioni IEC / IEC Dimensions										
	56 B5	56 B14	63 B5	63 B14	71 B5	71 B14	80 B5	80 B14	90 B5	90 B14
N	80	50	95	60	110	70	130	80	130	95
M	100	65	115	75	130	85	165	100	165	115
P	120	80	140	90	160	105	200	120	200	140
	9		11		14		19		24	



FT Motoriduttori pendolari Helical parallel gearmotors

Dati tecnici

Technical data

P ₁ [kW]	n ₂ [min ⁻¹]	M ₂ [Nm]	sf	i			P ₁ [kW]	n ₂ [min ⁻¹]	M ₂ [Nm]	sf	i				
0.09							0.12								
56B4 (1400 min ⁻¹)	68	12	3.4	20.57	FT105/3	B14	63A4 (1400 min ⁻¹)	75	14	5.6	18.75	FT146	B5/B14		
	42	19	2.6	33.32			B14		53	20	4.0			26.17	B5/B14
	32	26	2.5	44.36			B14		50	22	3.7			28.26	B5/B14
	26	32	2.1	54.87			B14		40	27	3.7			35.07	B5/B14
	20	41	1.6	71.84			B14		35	30	3.3			39.44	B5/B14
	18	44	1.5	77.07			B14		30	36	2.8			46.44	B5/B14
	16	51	1.3	88.87			B14		26	41	2.5			52.86	B5/B14
	11	72	0.90	124.81			B14		23	47	2.4			60.63	B5/B14
	7.7	105	0.62	181.35			B14		20	54	2.0			70.00	B5/B14
	6.2	110	0.59	224.32			B14		17	65	1.7			84.63	B5/B14
	4.4	110	0.59	315.05	B14		15	74	1.5	95.61	B5/B14				
							12	87	1.3	113.40	B5/B14				
	3.8	120	0.54	368.19	FT105/4	B14	10	103	1.1	133.45	B5/B14				
	2.6	120	0.54	534.98			B14		9.3	116	0.95	150.18	B5/B14		
	2.1	120	0.54	661.76			B14		8.7	123	0.97	160.43	B5/B14		
	1.5	120	0.54	929.40			B14		7.8	138	0.87	178.83	B5/B14		
							6.3	172	0.70	223.92	B5/B14				
	75	11	7.4	18.75	FT146	B5/B14	0.18								
	53	15	5.3	26.17			B5/B14		63B4 (1400 min ⁻¹)	75	22	3.7	18.75	FT146	B5/B14
	50	16	4.9	28.26			B5/B14		53	30	2.6	26.17	B5/B14		
	40	20	4.9	35.07			B5/B14		50	33	2.5	28.26	B5/B14		
	35	23	4.4	39.44			B5/B14		40	40	2.5	35.07	B5/B14		
	30	27	3.7	46.44			B5/B14		40	40	2.5	35.07	B5/B14		
	27	31	3.3	52.86			B5/B14		35	46	2.2	39.44	B5/B14		
	23	35	3.1	60.63			B5/B14		30	54	1.9	46.44	B5/B14		
	20	40	2.7	70.00			B5/B14		26	61	1.6	52.86	B5/B14		
	17	49	2.3	84.63			B5/B14		23	70	1.6	60.63	B5/B14		
	15	55	2.0	95.61	B5/B14		20	81	1.4	70.00	B5/B14				
	12	65	1.7	113.40	B5/B14		17	98	1.1	84.63	B5/B14				
	10	77	1.4	133.45	B5/B14		15	110	1.0	95.61	B5/B14				
	9.3	87	1.3	150.18	B5/B14		12	131	0.84	113.40	B5/B14				
	8.7	93	1.3	160.43	B5/B14		10	154	0.72	133.45	B5/B14				
	7.8	103	1.2	178.83	B5/B14		0.22								
	6.3	129	0.94	223.92	B5/B14		63C4 (1400 min ⁻¹)	75	26	3.0	18.75	FT146	B5/B14		
	5.9	137	0.88	236.83	B5/B14		53	37	2.2	26.17	B5/B14				
	4.7	170	0.70	300.07	B5/B14		50	40	2.0	28.26	B5/B14				
	3.5	170	0.70	397.38	B5/B14		40	49	2.0	35.07	B5/B14				
							35	56	1.8	39.44	B5/B14				
							30	66	1.5	46.44	B5/B14				
							26	75	1.3	52.86	B5/B14				
							23	86	1.3	60.63	B5/B14				
							20	99	1.1	70.00	B5/B14				
							17	119	0.93	84.63	B5/B14				
							15	135	0.82	95.61	B5/B14				



N.B.
Verificare sempre che la coppia M2 utilizzata non ecceda il valore indicato nelle caselle in grigio

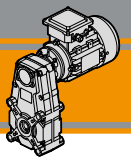

N.B.
Please check that the output torque M2 does not exceed the value in the grey areas







Dati tecnici

Technical data

P ₁ [kW]	n ₂ [min ⁻¹]	M ₂ [Nm]	sf	i				
0.25								
71A4 (1400 min ⁻¹)	75	30	2.7	18.75	FT146	B5/B14		
	53	42	1.9	26.17		B5/B14		
	50	45	1.8	28.26		B5/B14		
	40	56	1.8	35.07		B5/B14		
	35	63	1.6	39.44		B5/B14		
	30	74	1.3	46.44		B5/B14		
	26	85	1.2	52.86		B5/B14		
	23	97	1.1	60.63		B5/B14		
	20	112	0.98	70.00		B5/B14		
	17	136	0.81	84.63		B5/B14		
	15	153	0.72	95.61		B5/B14		
	69	33	10.7	20.41		FT196	B5/B14	
		40	56	7.2			34.81	B5/B14
		33	68	6.6			42.61	B5/B14
24		95	5.3	59.36	B5/B14			
19		117	4.7	72.68	B5/B14			
15		149	3.7	92.82	B5/B14			
11		199	2.8	123.95	B5/B14			
8.9		253	2.2	158.02	B5/B14			
6.9	323	1.7	201.80	B5/B14				
	5.2	432	1.3	269.47	B5/B14			

P ₁ [kW]	n ₂ [min ⁻¹]	M ₂ [Nm]	sf	i		
0.75						
80B4 (1400 min ⁻¹)	69	98	3.6	20.41	FT196	B5/B14
	40	167	2.4	34.81		B5/B14
	33	205	2.2	42.61		B5/B14
	24	285	1.8	59.36		B5/B14
	19	350	1.6	72.68		B5/B14
	15	446	1.2	92.82		B5/B14
	11	596	0.92	123.95		B5/B14
1.1						
90S4 (1400 min ⁻¹)	69	144	2.4	20.41	FT196	B5/B14
	40	246	1.6	34.81		B5/B14
	33	301	1.5	42.61		B5/B14
	24	419	1.2	59.36		B5/B14
	19	513	1.1	72.68		B5/B14
	15	655	0.84	92.82		B5/B14
1.5						
90L4 (1400 min ⁻¹)	69	196	1.8	20.41	FT196	B5/B14
	40	335	1.2	34.81		B5/B14
	33	410	1.1	42.61		B5/B14
	24	571	0.88	59.36		B5/B14
	19	699	0.79	72.68		B5/B14

P ₁ [kW]	n ₂ [min ⁻¹]	M ₂ [Nm]	sf	i				
0.37								
71B4 (1400 min ⁻¹)	75	44	1.8	18.75	FT146	B5/B14		
	53	62	1.3	26.17		B5/B14		
	50	67	1.2	28.26		B5/B14		
	40	83	1.2	35.07		B5/B14		
	35	94	1.1	39.44		B5/B14		
	30	110	0.91	46.44		B5/B14		
	26	125	0.80	52.86		B5/B14		
	23	144	0.76	60.63		B5/B14		
	69	48	7.2	20.41		FT196	B5/B14	
		40	83	4.8			34.81	B5/B14
		33	101	4.5			42.61	B5/B14
		24	141	3.6			59.36	B5/B14
		19	172	3.2			72.68	B5/B14
		15	220	2.5			92.82	B5/B14
11		294	1.9	123.95	B5/B14			
8.9		375	1.5	158.02	B5/B14			
6.9	479	1.1	201.80	B5/B14				
	5.2	639	0.86	269.47	B5/B14			

P ₁ [kW]	n ₂ [min ⁻¹]	M ₂ [Nm]	sf	i		
0.55						
80A4 (1400 min ⁻¹)	69	72	4.9	20.41	FT196	B5/B14
	40	123	3.2	34.81		B5/B14
	33	150	3.0	42.61		B5/B14
	24	209	2.4	59.36		B5/B14
	19	255	2.1	72.68		B5/B14
	15	327	1.7	92.82		B5/B14
	11	437	1.3	123.95		B5/B14
	8.9	557	1.0	158.02		B5/B14
	6.9	712	0.77	201.80		B5/B14

FT

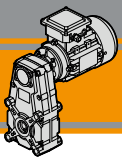

FT 105

FT 105...U

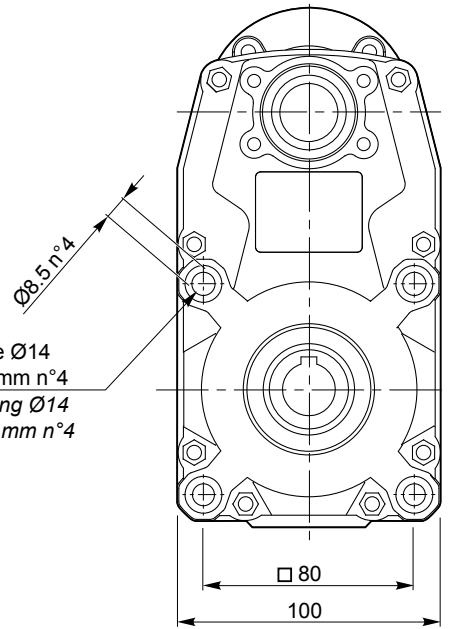
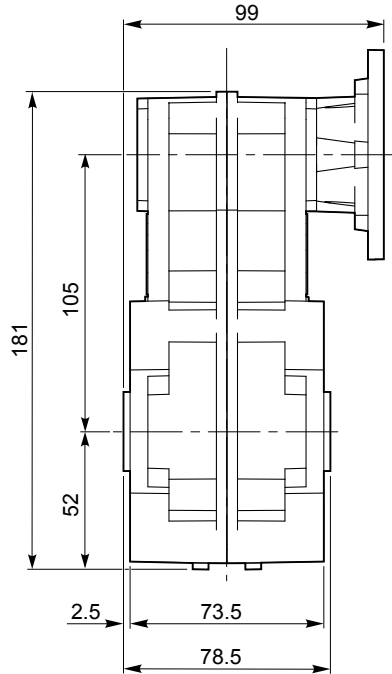

Kg 4.2

NOTA: Stessi fissaggi da entrambi i lati
NOTE: Same fixing points in both sides

IEC Motori applicabili
IEC Motor adapters

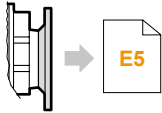

O17

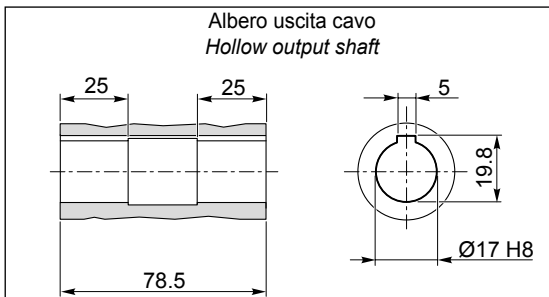

O20

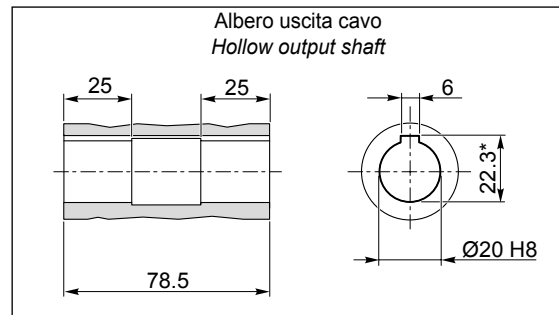

*: Sede linguetta ribassata / Special keyway

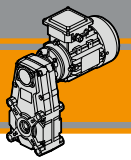

FT 146

FT 146 U

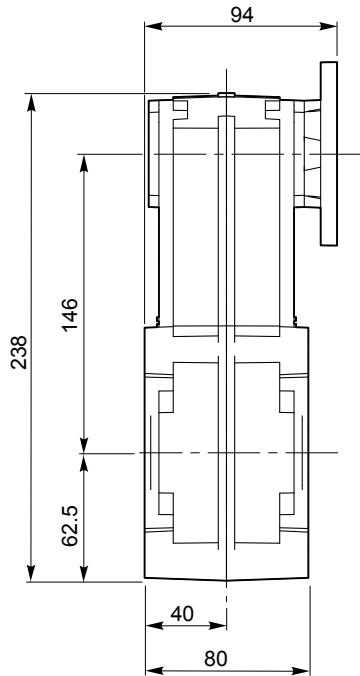

Lamature Ø14
Prof. 9.5 mm n°4
Spot-facing Ø14
Deep 9.5 mm n°4

Kg 4.7

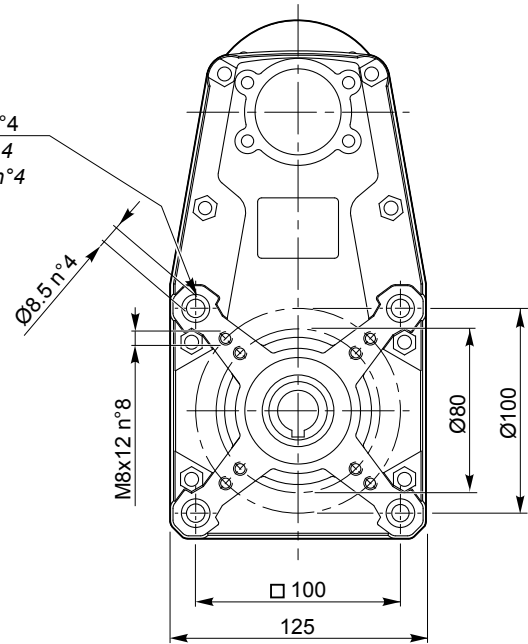

NOTA: Stessi fissaggi da entrambi i lati
NOTE: Same fixing points in both sides

IEC Motori applicabili
IEC Motor adapters



O20

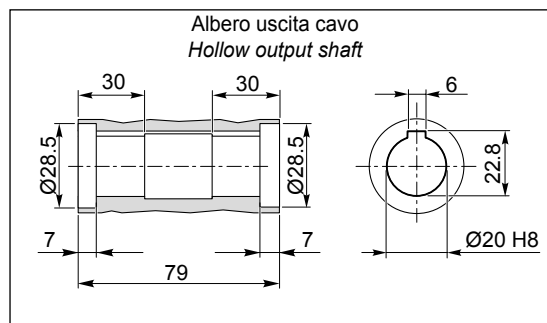

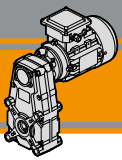

FT 196

FT 196 U

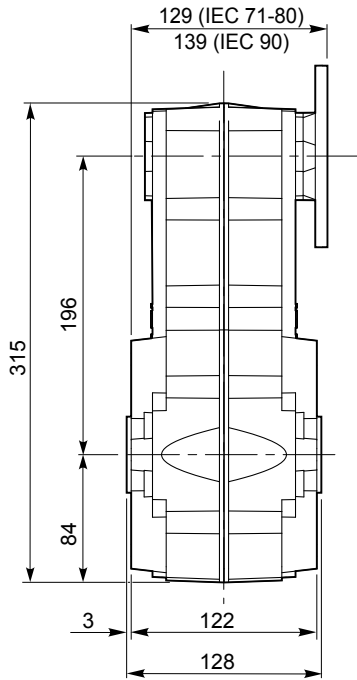

Lamature Ø14
Prof. 11 mm n°4
Spot-facing Ø14
Deep 11 mm n°4

Kg 12.1

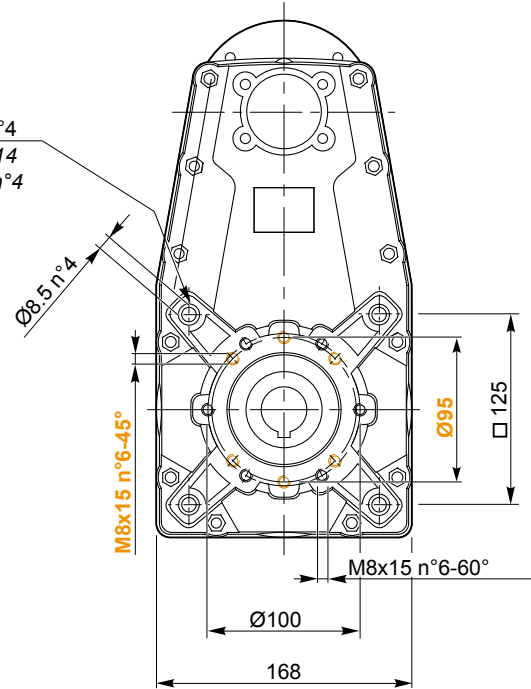

NOTA: Stessi fissaggi da entrambi i lati
NOTE: Same fixing points in both sides

IEC Motori applicabili
IEC Motor adapters

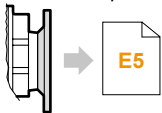

O30

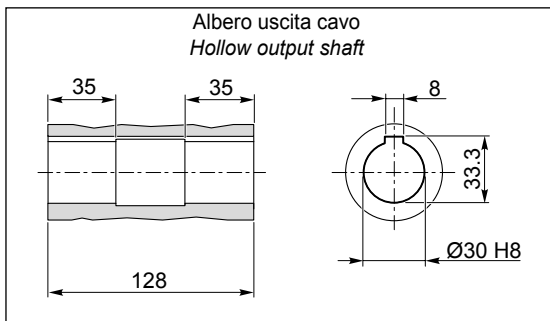

O35

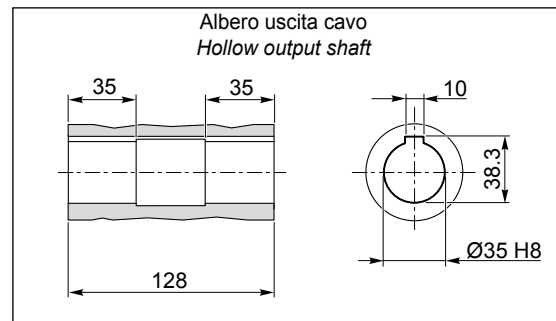



MA TRANSTECNO S.A.P.I. DE C.V.
 Av. Mundial # 176, Parque Industrial
 JM Apodaca, Nuevo León,
 C.P. 66600
 MÉXICO
 T +52 8113340920
 info@transtecno.com.mx
 www.transtecno.com.mx



TRANSTECNO SRL
 Via Caduti di Sabbiano, 11/D-E
 40011 Anzola dell'Emilia (BO)
 ITALY
 T+39 051 64 25 811
 F +39 051 73 39 04
 sales@transtecno.com
 www.transtecno.com



**HANGZHOU TRANSTECNO POWER
 TRANSMISSIONS CO LTD**
 No.4 Xiuyan Road Fengdu Industry Zone
 Pingyao Town Yuhang District
 Hangzhou City, Zhejiang Province
 311115 – CHINA
 T +86 571 86 92 02 60
 F +86 571 86 92 18 10
 info-china@transtecno.com
 www.transtecno.cn



TRANSTECNO U.S.A. LLC
 5440 S.W. 156th Place Miami,
 FL 33185 - USA
 Tel: +1 (305) 220-4423
 Fax: +1 (305) 220-5945
 usaoffice@transtecno.com



TRANSTECNO B.V.
 Ind. terrein Wieken/Vinkenhof
 De Stuwdam,43
 3815 KM Amersfoort - NETHERLANDS
 Tel: +31(0) 33 45 19 505
 Fax: +31(0) 33 45 19 506
 info@transtecno.nl
 www.transtecno.nl



SALES OFFICE INDIA
 A/10, Anagha, S.N. Road, Mulund (W) Mumbai
 400080 - INDIA
 Tel: +91 9820614698
 Fax-Italy: +39 051 733 904
 indiaoffice@transtecno.com



SALES OFFICE BRAZIL
 Rua Dr. Freire Alemão 155 / 402 - CEP. 90450-060
 Auxiliadora Porto Alegre RS - BRAZIL
 Tel: +55 51 3251 5447
 Fax: +55 51 3251 5447
 Mobile: +55 51 811 45 962
 braziloffice@transtecno.com
 www.transtecno.com.br



**TRANSTECNO IBÉRICA
 THE MODULAR GEARMOTOR, S.A.**
 C/Enginy, 2 Nave 6 - 08850 Gavà (Barcelona) - SPAIN
 Tel: +34 931 598 950
 info@transtecno.es
 www.transtecno.es



SALES OFFICE SOUTH KOREA
 D-304 Songdo BRC Smart Valley 30, Songdomirae-ro,
 Yeonsu-gu, Incheon, 406-840 - KOREA
 Tel: +82 70 8288 2107
 Fax: +82 32 815 2107
 Mobile: +82 10 5094 2107
 koreaoffice@transtecno.com



SALES OFFICE FRANCE
 12 Impasse des Mûriers
 38300 Ruy - FRANCE
 Tel: +33 (0) 6 85 12 09 87
 Fax-Italy: +39 051 733 904
 franceoffice@transtecno.com
 www.transtecno.fr



SALES OFFICE OCEANIA
 44 Northview drive, Sunshine west 3020
 Victoria - AUSTRALIA
 Ph +61 03 9312 4722
 Fax +61 03 9312 4714
 Mobile: +61 0438060997
 oceaniaoffice@transtecno.com
 www.transtecno.com.au

TRANSTECNO®
 the modular gearmotor
 www.transtecno.com